



Message Implementation Guideline

EURO-LOG AIR/SEA/ROAD/RAIL FREIGHT TMS IFTSTA

based on

IFTSTA

International multimodal status report message

UN D.01B S3

Version: 1
Variant: 7
Issue date: 9/24/2024
Author: Stefan Löffler

EURO-LOG AIR/SEA/ROAD/RAIL FREIGHT TMS IFTSTA

Message Structure / Table of Contents

Counter	No	Tag	St	MaxOcc	Name
0000	1	UNA	C	1	Service string advice
0000	2	UNB	M	1	Interchange header
0010	3	UNH	M	1	Message header
0020	4	BGM	M	1	Beginning of message
0030	5	DTM	C	9	Date/time/period
0160		SG4	C	99999	CNI-SG5
0170	6	CNI	M	1	Consignment information
0200		SG5	R	99	STS-RFF-RFF-RFF-RFF-RFF-RFF-RFF-RFF-RFF-DTM-FTX-SG6-SG6-LOC-SG8-SG10
0210	7	STS	M	1	Status
0220	8	RFF	C	1	Reference
0220	9	RFF	C	1	Reference
0220	10	RFF	C	1	Reference
0220	11	RFF	C	1	Reference
0220	12	RFF	C	1	Reference
0220	13	RFF	C	1	Reference
0220	14	RFF	C	1	Reference
0220	15	RFF	C	1	Reference
0220	16	RFF	C	1	Reference
0220	17	RFF	C	1	Reference
0230	18	DTM	C	99	Date/time/period
0250	19	FTX	C	9	Free text
0260		SG6	C	9	NAD
0270	20	NAD	M	1	Name and address
0260		SG6	C	9	NAD
0270	21	NAD	M	1	Name and address
0310	22	LOC	C	1	Place/location identification
0330		SG8	C	99	TDT
0340	23	TDT	M	1	Details of transport
0400		SG10	C	99	EQD-MEA-SEL
0410	24	EQD	M	1	Equipment details
0420	25	MEA	C	9	Measurements
0440	26	SEL	C	9	Seal number
0660	27	UNT	M	1	Message trailer
0000	28	UNZ	M	1	Interchange trailer

No = Consecutive segment number
 MaxOcc = Maximum occurrence of the segment/group
 Counter = Counter of segment/group within the standard

St = Status
 EDIFACT: M=Mandatory, C=Conditional
 User specific: R=Required, O=Optional, D=Dependent,
 A=Advised, N=Not used

EURO-LOG AIR/SEA/ROAD/RAIL FREIGHT TMS IFTSTA

Branching Diagram

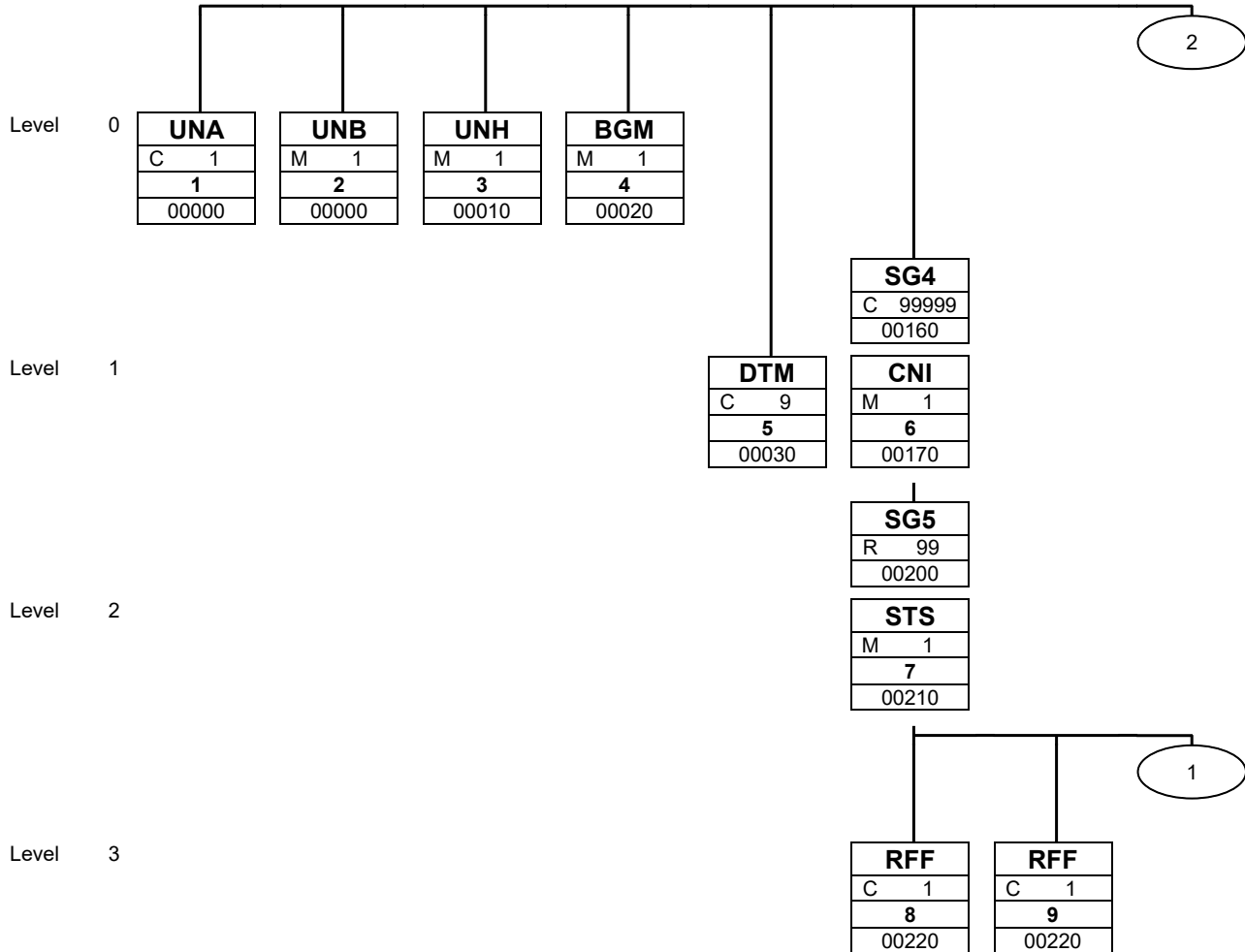

Tag
St MaxOcc
No
Counter

Tag = Segment/Group Tag
 St = Status (M=Mandatory, C=Conditional, R=Required, O=Optional, A=Advised, D=Dependent)
 MaxOcc = Maximum occurrence of the segment/group
 No = Consecutive segment number
 Counter = Counter of segment/group within the standard

EURO-LOG AIR/SEA/ROAD/RAIL FREIGHT TMS IFTSTA

Branching Diagram

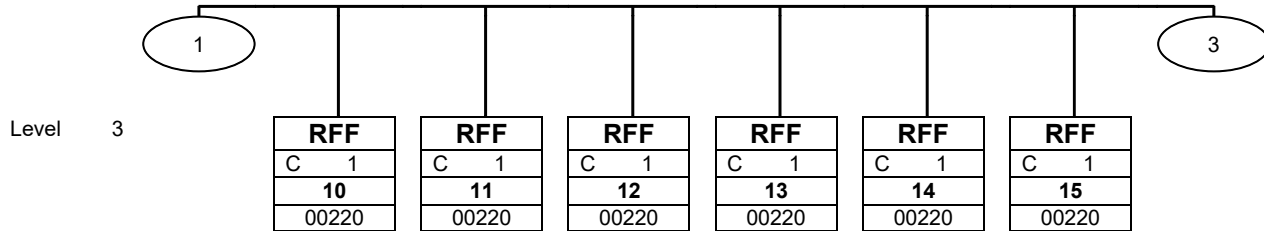

Tag
St MaxOcc
No
Counter

Tag = Segment/Group Tag
 St = Status (M=Mandatory, C=Conditional, R=Required, O=Optional, A=Advised, D=Dependent)
 MaxOcc = Maximum occurrence of the segment/group
 No = Consecutive segment number
 Counter = Counter of segment/group within the standard

EURO-LOG AIR/SEA/ROAD/RAIL FREIGHT TMS IFTSTA

Branching Diagram

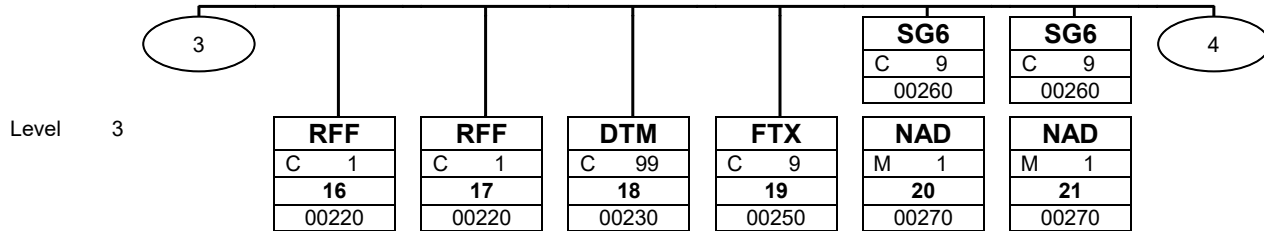

Tag
St MaxOcc
No
Counter

Tag = Segment/Group Tag
 St = Status (M=Mandatory, C=Conditional, R=Required, O=Optional, A=Advised, D=Dependent)
 MaxOcc = Maximum occurrence of the segment/group
 No = Consecutive segment number
 Counter = Counter of segment/group within the standard

EURO-LOG AIR/SEA/ROAD/RAIL FREIGHT TMS IFTSTA

Branching Diagram

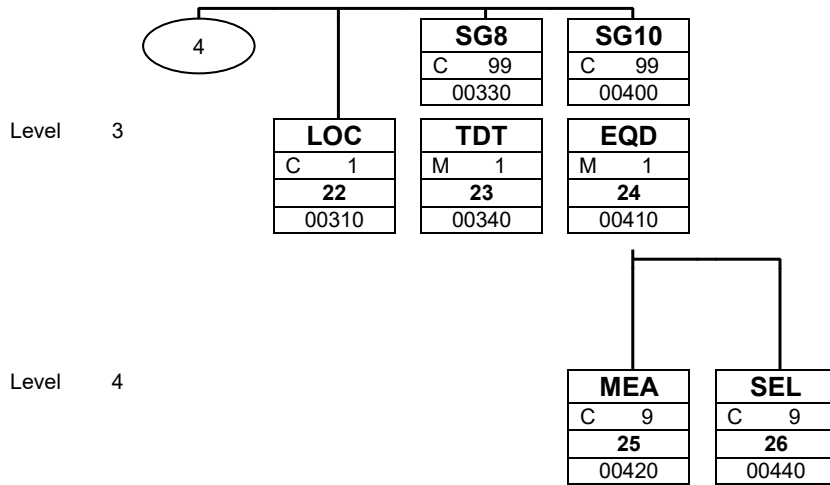

Tag
St MaxOcc
No
Counter

Tag = Segment/Group Tag
 St = Status (M=Mandatory, C=Conditional, R=Required, O=Optional, A=Advised, D=Dependent)
 MaxOcc = Maximum occurrence of the segment/group
 No = Consecutive segment number
 Counter = Counter of segment/group within the standard

EURO-LOG AIR/SEA/ROAD/RAIL FREIGHT TMS IFTSTA

Branching Diagram

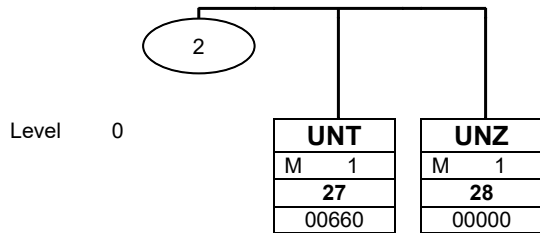

Tag
St MaxOcc
No
Counter

Tag = Segment/Group Tag
 St = Status (M=Mandatory, C=Conditional, R=Required, O=Optional, A=Advised, D=Dependent)
 MaxOcc = Maximum occurrence of the segment/group
 No = Consecutive segment number
 Counter = Counter of segment/group within the standard

EURO-LOG AIR/SEA/ROAD/RAIL FREIGHT TMS IFTSTA

Segments

Segment: **UNA** No: 1 Level: 0 Counter: 0000
 Status: C MaxOcc: 1 **Service string advice**

		Standard	Implementation	
Tag	Name	St Format	St Format	Usage / Remarks
UNA				
UNA1	Component data element separator	M an1	M an1	
UNA2	Data element separator	M an1	M an1	
UNA3	Decimal notation	M an1	M an1	
UNA4	Release indicator	M an1	M an1	
UNA5	Reserved for future use	M an1	M an1	
UNA6	Segment terminator	M an1	M an1	

Remark:

Example:
 UNA: + . ? ' '

No = Consecutive segment number
 MaxOcc = Maximum occurrence of the segment/group
 Counter = Counter of segment/group within the standard

St = Status
 EDIFACT: M=Mandatory, C=Conditional
 User specific: R=Required, O=Optional, D=Dependent,
 A=Advised, N=Not used

EURO-LOG AIR/SEA/ROAD/RAIL FREIGHT TMS IFTSTA

Segments

Segment: **UNB** No: 2 Level: 0 Counter: 0000
 Status: M MaxOcc: 1 Interchange header

		Standard	Implementation	
Tag	Name	St Format	St Format	Usage / Remarks
UNB				
S001	Syntax identifier	M	M	
0001	Syntax identifier	M a4	M a4	
0002	Syntax version number	M n1	M n1	
S002	Interchange sender	M	M	
0004	Sender identification	M an..35	M an..35	Sender ID (TOMS system)
0007	Partner identification code qualifier	C an..4	N an..4	Not used
0008	Address for reverse routing	C an..14	N an..14	Not used
S003	Interchange recipient	M	M	
0010	Recipient identification	M an..35	M an..35	
0007	Partner identification code qualifier	C an..4	N an..4	Not used
0014	Routing address	C an..14	N an..14	Not used
S004	Date/time of preparation	M	M	
0017	Date of preparation	M n6	M n6	
0019	Time of preparation	M n4	M n4	
0020	Interchange control reference	M an..14	M an..14	
S005	Recipient's reference, password	C	N	
0022	Recipient's reference/password	M an..14	N an..14	Not used
0025	Recipient's reference/password qualifier	C an2	N an2	Not used
0026	Application reference	C an..14	N an..14	Not used
0029	Processing priority code	C a1	N a1	Not used
0031	Acknowledgement request	C n1	N n1	Not used
0032	Communications agreement ID	C an..35	N an..35	Not used
0035	Test indicator	C n1	N n1	Not used

Remark:

Example:

UNB+UNOC:3+Sender+EUROLOG+191017:1616+X'

No = Consecutive segment number
 MaxOcc = Maximum occurrence of the segment/group
 Counter = Counter of segment/group within the standard

St = Status
 EDIFACT: M=Mandatory, C=Conditional
 User specific: R=Required, O=Optional, D=Dependent,
 A=Advised, N=Not used

EURO-LOG AIR/SEA/ROAD/RAIL FREIGHT TMS IFTSTA

Segments

Segment: **UNH** No: 3 Level: 0 Counter: 0010
 Status: M MaxOcc: 1 Message header

		Standard	Implementation	
Tag	Name	St Format	St Format	Usage / Remarks
UNH				
0062	Message reference number	M an..14	M an..14	
S009	Message identifier	M	M	
0065	Message type	M an..6	M an..6	
0052	Message version number	M an..3	M an..3	
0054	Message release number	M an..3	M an..3	
0051	Controlling agency	M an..2	M an..2	
0057	Association assigned code	C an..6	N an..6	Not used
0068	Common access reference	C an..35	N an..35	Not used
S010	Status of the transfer	C	N	
0070	Sequence of transfers	M n..2	N n..2	Not used
0073	First and last transfer	C a1	N a1	Not used

Remark:

Example:

UNH+X+IFTSTA:D:01B:UN'

No = Consecutive segment number
 MaxOcc = Maximum occurrence of the segment/group
 Counter = Counter of segment/group within the standard

St = Status
 EDIFACT: M=Mandatory, C=Conditional
 User specific: R=Required, O=Optional, D=Dependent,
 A=Advised, N=Not used

EURO-LOG AIR/SEA/ROAD/RAIL FREIGHT TMS IFTSTA

Segments

Segment: **BGM** No: 4 Level: 0 Counter: 0020
 Status: M MaxOcc: 1 **Beginning of message**

		Standard	Implementation	
Tag	Name	St Format	St Format	Usage / Remarks
BGM				
C002	Document/message name	C	C	
1001	Document name code	C an..3	C an..3	7 Process data report
1131	Code list identification code	C an..17	N an..17	Not used
3055	Code list responsible agency code	C an..3	N an..3	Not used
1000	Document name	C an..35	N an..35	Not used
C106	Document/message identification	C	C	
1004	Document identifier	C an..35	C an..35	
1056	Version identifier	C an..9	N an..9	Not used
1060	Revision identifier	C an..6	N an..6	Not used
1225	Message function code	C an..3	C an..3	9 Original
4343	Response type code	C an..3	N an..3	Not used

Remark:

Example:

BGM+7+X+9'

No = Consecutive segment number
 MaxOcc = Maximum occurrence of the segment/group
 Counter = Counter of segment/group within the standard

St = Status
 EDIFACT: M=Mandatory, C=Conditional
 User specific: R=Required, O=Optional, D=Dependent,
 A=Advised, N=Not used

EURO-LOG AIR/SEA/ROAD/RAIL FREIGHT TMS IFTSTA

Segments

Segment: **DTM** No: 5 Level: 1 Counter: 0030
 Status: C MaxOcc: 9 Date/time/period

		Standard	Implementation	
Tag	Name	St Format	St Format	Usage / Remarks
DTM				
C507	Date/time/period	M	M	
2005	Date or time or period function code qualifier	M an..3	M an..3	137 Document/message date/time
2380	Date or time or period value	C an..35	C an..35	
2379	Date or time or period format code	C an..3	C an..3	203 CCYYMMDDHHMM

Remark:

Example:

DTM+137:201906281331:203'

No = Consecutive segment number
 MaxOcc = Maximum occurrence of the segment/group
 Counter = Counter of segment/group within the standard

St = Status
 EDIFACT: M=Mandatory, C=Conditional
 User specific: R=Required, O=Optional, D=Dependent,
 A=Advised, N=Not used

EURO-LOG AIR/SEA/ROAD/RAIL FREIGHT TMS IFTSTA

Segments

Group: **SG4** Status: C MaxOcc: 99999 Counter: 0160
CNI-SG5
Segment: **CNI** No: 6 Level: 1 Counter: 0170
Status: M MaxOcc: 1 **Consignment information**

		Standard	Implementation	
Tag	Name	St Format	St Format	Usage / Remarks
CNI				
1490	Consolidation item number	C n..4	C n..4	
C503	Document/message details	C	C	
1004	Document identifier	C an..35	C an..35	Consignment number
1373	Document status code	C an..3	N an..3	Not used
1366	Document source description	C an..70	N an..70	Not used
3453	Language name code	C an..3	N an..3	Not used
1056	Version identifier	C an..9	N an..9	Not used
1060	Revision identifier	C an..6	N an..6	Not used
1312	Consignment load sequence identifier	C n..4	N n..4	Not used

Remark:

Example:

CNI+1+SONXXXXXXXXXX'

No = Consecutive segment number
MaxOcc = Maximum occurrence of the segment/group
Counter = Counter of segment/group within the standard

St = Status
EDIFACT: M=Mandatory, C=Conditional
User specific: R=Required, O=Optional, D=Dependent,
A=Advised, N=Not used

EURO-LOG AIR/SEA/ROAD/RAIL FREIGHT TMS IFTSTA

Segments

Group:	SG4	Status: C	MaxOcc: 99999	Counter: 0160 CNI-SG5
Group:	SG5	Status: R	MaxOcc: 99	Counter: 0200 STS-RFF-DTM-FTX-SG6-LOC-SG8-SG10
Segment:	STS	No: 7 Status: M	Level: 2 MaxOcc: 1	Counter: 0210 Status

		Standard	Implementation	
Tag	Name	St Format	St Format	Usage / Remarks
STS				
C601	Status category	C	C	
9015	Status category code	M an..3	M an..3	1 Transport
1131	Code list identification code	C an..17	N an..17	Not used
3055	Code list responsible agency code	C an..3	N an..3	Not used
C555	Status	C	C	
4405	Status description code	M an..3	M an..3	13 Collected at pick-up 21 Delivered at destination 22 (Partially) Damaged 23 Partially Delivered 30 Information status 41 No Pick-up Possible 98 Order booked 99 Reject/Decline transport order 212 New delivery date 213 Collected at Terminal 221 Delivered at Terminal 300 In transit 312 Arrival notice message received 313 Out for Delivery AIR AIR - booked SEA SEA - booked CUS CUSTOMS - booked ATR AIR - in transit STR SEA - in transit 321 Goods receipt, sent by customer (Buyer only) 490 Shipment closed (Buyer only) 495 Load partially closed (Buyer only) 499 Load closed (Buyer only)
1131	Code list identification code	C an..17	N an..17	Not used
3055	Code list responsible agency code	C an..3	N an..3	Not used
4404	Status description	C an..35	N an..35	Not used
C556	Status reason	C	N	
9013	Status reason description code	M an..3	N an..3	Not used
1131	Code list identification code	C an..17	N an..17	Not used
3055	Code list responsible agency code	C an..3	N an..3	Not used
9012	Status reason description	C an..256	N an..256	Not used

No = Consecutive segment number
 MaxOcc = Maximum occurrence of the segment/group
 Counter = Counter of segment/group within the standard

St = Status
 EDIFACT: M=Mandatory, C=Conditional
 User specific: R=Required, O=Optional, D=Dependent,
 A=Advised, N=Not used

EURO-LOG AIR/SEA/ROAD/RAIL FREIGHT TMS IFTSTA

Segments

		Standard	Implementation	
Tag	Name	St Format	St Format	Usage / Remarks
C556	Status reason	C	N	
9013	Status reason description code	M an..3	N an..3	Not used
1131	Code list identification code	C an..17	N an..17	Not used
3055	Code list responsible agency code	C an..3	N an..3	Not used
9012	Status reason description	C an..256	N an..256	Not used
C556	Status reason	C	N	
9013	Status reason description code	M an..3	N an..3	Not used
1131	Code list identification code	C an..17	N an..17	Not used
3055	Code list responsible agency code	C an..3	N an..3	Not used
9012	Status reason description	C an..256	N an..256	Not used
C556	Status reason	C	N	
9013	Status reason description code	M an..3	N an..3	Not used
1131	Code list identification code	C an..17	N an..17	Not used
3055	Code list responsible agency code	C an..3	N an..3	Not used
9012	Status reason description	C an..256	N an..256	Not used
C556	Status reason	C	N	
9013	Status reason description code	M an..3	N an..3	Not used
1131	Code list identification code	C an..17	N an..17	Not used
3055	Code list responsible agency code	C an..3	N an..3	Not used
9012	Status reason description	C an..256	N an..256	Not used

Remark:

Example:

STS+1+13'

No = Consecutive segment number
 MaxOcc = Maximum occurrence of the segment/group
 Counter = Counter of segment/group within the standard

St = Status
 EDIFACT: M=Mandatory, C=Conditional
 User specific: R=Required, O=Optional, D=Dependent,
 A=Advised, N=Not used

EURO-LOG AIR/SEA/ROAD/RAIL FREIGHT TMS IFTSTA

Segments

Group:	SG4	Status: C	MaxOcc: 99999	Counter: 0160 CNI-SG5
Group:	SG5	Status: R	MaxOcc: 99	Counter: 0200 STS-RFF-DTM-FTX-SG6-LOC-SG8-SG10
Segment:	RFF	No: 8 Status: C	Level: 3 MaxOcc: 1	Counter: 0220 Reference

		Standard	Implementation	
Tag	Name	St Format	St Format	Usage / Remarks
RFF				
C506	Reference	M	M	
1153	Reference code qualifier	M an..3	M an..3	AAZ Standard Carrier Alpha Code (SCAC) number
1154	Reference identifier	C an..70	C an..70	
1156	Document line identifier	C an..6	N an..6	Not used
4000	Reference version identifier	C an..35	N an..35	Not used
1060	Revision identifier	C an..6	N an..6	Not used

Remark:

Example:

RFF+AAZ : XXXXXXXXXXXX '

No = Consecutive segment number
 MaxOcc = Maximum occurrence of the segment/group
 Counter = Counter of segment/group within the standard

St = Status
 EDIFACT: M=Mandatory, C=Conditional
 User specific: R=Required, O=Optional, D=Dependent,
 A=Advised, N=Not used

EURO-LOG AIR/SEA/ROAD/RAIL FREIGHT TMS IFTSTA

Segments

Group:	SG4	Status: C	MaxOcc: 99999	Counter: 0160 CNI-SG5
Group:	SG5	Status: R	MaxOcc: 99	Counter: 0200 STS-RFF-DTM-FTX-SG6-LOC-SG8-SG10
Segment:	RFF	No: 9 Status: C	Level: 3 MaxOcc: 1	Counter: 0220 Reference

		Standard	Implementation	
Tag	Name	St Format	St Format	Usage / Remarks
RFF				
C506	Reference	M	M	
1153	Reference code qualifier	M an..3	M an..3	BL Master bill of lading number
1154	Reference identifier	C an..70	C an..70	
1156	Document line identifier	C an..6	N an..6	Not used
4000	Reference version identifier	C an..35	N an..35	Not used
1060	Revision identifier	C an..6	N an..6	Not used

Remark:

Example:

RFF+BL:XXXXXXXXXX'

No = Consecutive segment number
 MaxOcc = Maximum occurrence of the segment/group
 Counter = Counter of segment/group within the standard

St = Status
 EDIFACT: M=Mandatory, C=Conditional
 User specific: R=Required, O=Optional, D=Dependent,
 A=Advised, N=Not used

EURO-LOG AIR/SEA/ROAD/RAIL FREIGHT TMS IFTSTA

Segments

Group:	SG4	Status: C	MaxOcc: 99999	Counter: 0160 CNI-SG5
Group:	SG5	Status: R	MaxOcc: 99	Counter: 0200 STS-RFF-DTM-FTX-SG6-LOC-SG8-SG10
Segment:	RFF	No: 10 Status: C	Level: 3 MaxOcc: 1	Counter: 0220 Reference

		Standard	Implementation	
Tag	Name	St Format	St Format	Usage / Remarks
RFF				
C506	Reference	M	M	
1153	Reference code qualifier	M an..3	M an..3	BN Booking reference number
1154	Reference identifier	C an..70	C an..70	
1156	Document line identifier	C an..6	N an..6	Not used
4000	Reference version identifier	C an..35	N an..35	Not used
1060	Revision identifier	C an..6	N an..6	Not used

Remark:

Example:

RFF+BN:XXXXXXXXXX'

No = Consecutive segment number
MaxOcc = Maximum occurrence of the segment/group
Counter = Counter of segment/group within the standard

St = Status
EDIFACT: M=Mandatory, C=Conditional
User specific: R=Required, O=Optional, D=Dependent,
A=Advised, N=Not used

EURO-LOG AIR/SEA/ROAD/RAIL FREIGHT TMS IFTSTA

Segments

Group:	SG4	Status: C	MaxOcc: 99999	Counter: 0160 CNI-SG5
Group:	SG5	Status: R	MaxOcc: 99	Counter: 0200 STS-RFF-DTM-FTX-SG6-LOC-SG8-SG10
Segment:	RFF	No: 11 Status: C	Level: 3 MaxOcc: 1	Counter: 0220 Reference

		Standard	Implementation	
Tag	Name	St Format	St Format	Usage / Remarks
RFF				
C506	Reference	M	M	
1153	Reference code qualifier	M an..3	M an..3	CMR CMR number
1154	Reference identifier	C an..70	C an..70	
1156	Document line identifier	C an..6	N an..6	Not used
4000	Reference version identifier	C an..35	N an..35	Not used
1060	Revision identifier	C an..6	N an..6	Not used

Remark:

Example:

RFF+CMR:XXXXXXXXXX'

No = Consecutive segment number
 MaxOcc = Maximum occurrence of the segment/group
 Counter = Counter of segment/group within the standard

St = Status
 EDIFACT: M=Mandatory, C=Conditional
 User specific: R=Required, O=Optional, D=Dependent,
 A=Advised, N=Not used

EURO-LOG AIR/SEA/ROAD/RAIL FREIGHT TMS IFTSTA

Segments

Group:	SG4	Status: C	MaxOcc: 99999	Counter: 0160 CNI-SG5
Group:	SG5	Status: R	MaxOcc: 99	Counter: 0200 STS-RFF-DTM-FTX-SG6-LOC-SG8-SG10
Segment:	RFF	No: 12 Status: C	Level: 3 MaxOcc: 1	Counter: 0220 Reference

		Standard	Implementation	
Tag	Name	St Format	St Format	Usage / Remarks
RFF				
C506	Reference	M	M	
1153	Reference code qualifier	M an..3	M an..3	CU Consignor's reference number
1154	Reference identifier	C an..70	C an..70	
1156	Document line identifier	C an..6	N an..6	Not used
4000	Reference version identifier	C an..35	N an..35	Not used
1060	Revision identifier	C an..6	N an..6	Not used

Remark:

Example:

RFF+CU:XXXXXXXXXX'

No = Consecutive segment number
MaxOcc = Maximum occurrence of the segment/group
Counter = Counter of segment/group within the standard

St = Status
EDIFACT: M=Mandatory, C=Conditional
User specific: R=Required, O=Optional, D=Dependent,
A=Advised, N=Not used

EURO-LOG AIR/SEA/ROAD/RAIL FREIGHT TMS IFTSTA

Segments

Group:	SG4	Status: C	MaxOcc: 99999	Counter: 0160 CNI-SG5
Group:	SG5	Status: R	MaxOcc: 99	Counter: 0200 STS-RFF-DTM-FTX-SG6-LOC-SG8-SG10
Segment:	RFF	No: 13 Status: C	Level: 3 MaxOcc: 1	Counter: 0220 Reference

		Standard	Implementation	
Tag	Name	St Format	St Format	Usage / Remarks
RFF				
C506	Reference	M	M	
1153	Reference code qualifier	M an..3	M an..3	CUS Customs identification number
1154	Reference identifier	C an..70	C an..70	
1156	Document line identifier	C an..6	N an..6	Not used
4000	Reference version identifier	C an..35	N an..35	Not used
1060	Revision identifier	C an..6	N an..6	Not used

Remark:

Example:

RFF+CUS:XXXXXXXXX'

No = Consecutive segment number
 MaxOcc = Maximum occurrence of the segment/group
 Counter = Counter of segment/group within the standard

St = Status
 EDIFACT: M=Mandatory, C=Conditional
 User specific: R=Required, O=Optional, D=Dependent,
 A=Advised, N=Not used

EURO-LOG AIR/SEA/ROAD/RAIL FREIGHT TMS IFTSTA

Segments

Group:	SG4	Status: C	MaxOcc: 99999	Counter: 0160 CNI-SG5
Group:	SG5	Status: R	MaxOcc: 99	Counter: 0200 STS-RFF-DTM-FTX-SG6-LOC-SG8-SG10
Segment:	RFF	No: 14 Status: C	Level: 3 MaxOcc: 1	Counter: 0220 Reference

		Standard	Implementation	
Tag	Name	St Format	St Format	Usage / Remarks
RFF				
C506	Reference	M	M	
1153	Reference code qualifier	M an..3	M an..3	FN Bordero number
1154	Reference identifier	C an..70	C an..70	
1156	Document line identifier	C an..6	N an..6	Not used
4000	Reference version identifier	C an..35	N an..35	Not used
1060	Revision identifier	C an..6	N an..6	Not used

Remark:

Example:

RFF+FN:XXXXXXXXXX'

No = Consecutive segment number
 MaxOcc = Maximum occurrence of the segment/group
 Counter = Counter of segment/group within the standard

St = Status
 EDIFACT: M=Mandatory, C=Conditional
 User specific: R=Required, O=Optional, D=Dependent,
 A=Advised, N=Not used

EURO-LOG AIR/SEA/ROAD/RAIL FREIGHT TMS IFTSTA

Segments

Group:	SG4	Status: C	MaxOcc: 99999	Counter: 0160 CNI-SG5
Group:	SG5	Status: R	MaxOcc: 99	Counter: 0200 STS-RFF-DTM-FTX-SG6-LOC-SG8-SG10
Segment:	RFF	No: 15 Status: C	Level: 3 MaxOcc: 1	Counter: 0220 Reference

		Standard	Implementation	
Tag	Name	St Format	St Format	Usage / Remarks
RFF				
C506	Reference	M	M	
1153	Reference code qualifier	M an..3	M an..3	HBL House bill of lading number
1154	Reference identifier	C an..70	C an..70	
1156	Document line identifier	C an..6	N an..6	Not used
4000	Reference version identifier	C an..35	N an..35	Not used
1060	Revision identifier	C an..6	N an..6	Not used

Remark:

Example:

RFF+HBL:XXXXXXXXXX'

No = Consecutive segment number
MaxOcc = Maximum occurrence of the segment/group
Counter = Counter of segment/group within the standard

St = Status
EDIFACT: M=Mandatory, C=Conditional
User specific: R=Required, O=Optional, D=Dependent,
A=Advised, N=Not used

EURO-LOG AIR/SEA/ROAD/RAIL FREIGHT TMS IFTSTA

Segments

Group:	SG4	Status: C	MaxOcc: 99999	Counter: 0160 CNI-SG5
Group:	SG5	Status: R	MaxOcc: 99	Counter: 0200 STS-RFF-DTM-FTX-SG6-LOC-SG8-SG10
Segment:	RFF	No: 16 Status: C	Level: 3 MaxOcc: 1	Counter: 0220 Reference

		Standard	Implementation	
Tag	Name	St Format	St Format	Usage / Remarks
RFF				
C506	Reference	M	M	
1153	Reference code qualifier	M an..3	M an..3	PBN Prebooking number
1154	Reference identifier	C an..70	C an..70	
1156	Document line identifier	C an..6	N an..6	Not used
4000	Reference version identifier	C an..35	N an..35	Not used
1060	Revision identifier	C an..6	N an..6	Not used

Remark:

Example:

RFF+PBN:XXXXXXXXX'

No = Consecutive segment number
 MaxOcc = Maximum occurrence of the segment/group
 Counter = Counter of segment/group within the standard

St = Status
 EDIFACT: M=Mandatory, C=Conditional
 User specific: R=Required, O=Optional, D=Dependent,
 A=Advised, N=Not used

EURO-LOG AIR/SEA/ROAD/RAIL FREIGHT TMS IFTSTA

Segments

Group:	SG4	Status: C	MaxOcc: 99999	Counter: 0160 CNI-SG5
Group:	SG5	Status: R	MaxOcc: 99	Counter: 0200 STS-RFF-DTM-FTX-SG6-LOC-SG8-SG10
Segment:	RFF	No: 17 Status: C	Level: 3 MaxOcc: 1	Counter: 0220 Reference

		Standard	Implementation	
Tag	Name	St Format	St Format	Usage / Remarks
RFF				
C506	Reference	M	M	
1153	Reference code qualifier	M an..3	M an..3	SRN Shipment reference number
1154	Reference identifier	C an..70	C an..70	
1156	Document line identifier	C an..6	N an..6	Not used
4000	Reference version identifier	C an..35	N an..35	Not used
1060	Revision identifier	C an..6	N an..6	Not used

Remark:

Example:

RFF+SRN:XXXXXXXXX'

No = Consecutive segment number
MaxOcc = Maximum occurrence of the segment/group
Counter = Counter of segment/group within the standard

St = Status
EDIFACT: M=Mandatory, C=Conditional
User specific: R=Required, O=Optional, D=Dependent,
A=Advised, N=Not used

EURO-LOG AIR/SEA/ROAD/RAIL FREIGHT TMS IFTSTA

Segments

Group:	SG4	Status: C	MaxOcc: 99999	Counter: 0160 CNI-SG5
Group:	SG5	Status: R	MaxOcc: 99	Counter: 0200 STS-RFF-DTM-FTX-SG6-LOC-SG8-SG10
Segment:	DTM	No: 18 Status: C	Level: 3 MaxOcc: 99	Counter: 0230 Date/time/period

		Standard	Implementation	
Tag	Name	St Format	St Format	Usage / Remarks
DTM				
C507	Date/time/period	M	M	
2005	Date or time or period function code qualifier	M an..3	M an..3	17 Delivery date/time, estimated 22 Freight bill date/time 35 Delivery date/time, actual 46 Cancellation date 70 House bill of lading date 95 Master bill of lading date 121 Arrived at customs 132 Arrival date/time, estimated 133 Departure date/time, estimated 143 Acceptance date/time of goods 178 Arrival date/time, actual 186 Departure date/time, actual 192 Blocked by customs 200 Pick-up/collection date/time of cargo 204 Release date (Customs) 408 Expected container hire from date/time
2380	Date or time or period value	C an..35	C an..35	
2379	Date or time or period format code	C an..3	C an..3	203 CCYYMMDDHHMM

Remark:

Example:

DTM+70:201906281244:203'

No = Consecutive segment number
 MaxOcc = Maximum occurrence of the segment/group
 Counter = Counter of segment/group within the standard

St = Status
 EDIFACT: M=Mandatory, C=Conditional
 User specific: R=Required, O=Optional, D=Dependent,
 A=Advised, N=Not used

EURO-LOG AIR/SEA/ROAD/RAIL FREIGHT TMS IFTSTA

Segments

Group:	SG4	Status: C	MaxOcc: 99999	Counter: 0160 CNI-SG5
Group:	SG5	Status: R	MaxOcc: 99	Counter: 0200 STS-RFF-DTM-FTX-SG6-LOC-SG8-SG10
Segment:	FTX	No: 19 Status: C	Level: 3 MaxOcc: 9	Counter: 0250 Free text

		Standard	Implementation	
Tag	Name	St Format	St Format	Usage / Remarks
FTX				
4451	Text subject code qualifier	M an..3	M an..3	TRA Transportation information VGM VGM Method HAN Handler REC Person handing over receipt CUS Customs broker REG Regulatory information URL Tracking URL
4453	Free text function code	C an..3	N an..3	Not used
C107	Text reference	C	N	
4441	Free text value code	M an..17	N an..17	Not used
1131	Code list identification code	C an..17	N an..17	Not used
3055	Code list responsible agency code	C an..3	N an..3	Not used
C108	Text literal	C	C	
4440	Free text value	M an..512	M an..512	In case of VGM: C (Calculated) / M (Measured)
4440	Free text value	C an..512	C an..512	In case of VGM: Creator
4440	Free text value	C an..512	C an..512	
4440	Free text value	C an..512	C an..512	
3453	Language name code	C an..3	N an..3	Not used
4447	Free text format code	C an..3	N an..3	Not used

Remark:

Example:

FTX+TRA+++X:X:X:X'

No = Consecutive segment number
MaxOcc = Maximum occurrence of the segment/group
Counter = Counter of segment/group within the standard

St = Status
EDIFACT: M=Mandatory, C=Conditional
User specific: R=Required, O=Optional, D=Dependent,
A=Advised, N=Not used

EURO-LOG AIR/SEA/ROAD/RAIL FREIGHT TMS IFTSTA

Segments

Group:	SG4	Status: C	MaxOcc: 99999	Counter: 0160 CNI-SG5
Group:	SG5	Status: R	MaxOcc: 99	Counter: 0200 STS-RFF-DTM-FTX-SG6-LOC-SG8-SG10
Group:	SG6	Status: C	MaxOcc: 9	Counter: 0260 NAD
Segment:	NAD	No: 20 Status: M	Level: 3 MaxOcc: 1	Counter: 0270 Name and address

		Standard	Implementation	
Tag	Name	St Format	St Format	Usage / Remarks
NAD				
3035	Party function code qualifier	M an..3	M an..3	TR Terminal operator
C082	Party identification details	C	C	
3039	Party identifier	M an..35	M an..35	Identifier of event location (e.g. ID, ISO-Code)
1131	Code list identification code	C an..17	N an..17	Not used
3055	Code list responsible agency code	C an..3	N an..3	Not used
C058	Name and address	C	C	
3124	Name and address description	M an..35	M an..35	POL Port of loading POD Port of discharge AOD Airport of departure AOA Airport of arrival
3124	Name and address description	C an..35	N an..35	Not used
3124	Name and address description	C an..35	N an..35	Not used
3124	Name and address description	C an..35	N an..35	Not used
3124	Name and address description	C an..35	N an..35	Not used
C080	Party name	C	N	
3036	Party name	M an..35	N an..35	Not used
3036	Party name	C an..35	N an..35	Not used
3036	Party name	C an..35	N an..35	Not used
3036	Party name	C an..35	N an..35	Not used
3036	Party name	C an..35	N an..35	Not used
3045	Party name format code	C an..3	N an..3	Not used
C059	Street	C	N	
3042	Street and number or post office box identifier	M an..35	N an..35	Not used
3042	Street and number or post office box identifier	C an..35	N an..35	Not used
3042	Street and number or post office box identifier	C an..35	N an..35	Not used
3042	Street and number or post office box identifier	C an..35	N an..35	Not used
3164	City name	C an..35	N an..35	Not used
C819	Country sub-entity details	C	N	
3229	Country sub-entity name code	C an..9	N an..9	Not used

No = Consecutive segment number
MaxOcc = Maximum occurrence of the segment/group
Counter = Counter of segment/group within the standard

St = Status
EDIFACT: M=Mandatory, C=Conditional
User specific: R=Required, O=Optional, D=Dependent,
A=Advised, N=Not used

EURO-LOG AIR/SEA/ROAD/RAIL FREIGHT TMS IFTSTA

Segments

		Standard	Implementation	
Tag	Name	St Format	St Format	Usage / Remarks
1131	Code list identification code	C an..17	N an..17	Not used
3055	Code list responsible agency code	C an..3	N an..3	Not used
3228	Country sub-entity name	C an..70	N an..70	Not used
3251	Postal identification code	C an..17	N an..17	Not used
3207	Country name code	C an..3	N an..3	Not used

Remark:

Example:

NAD+TR+X+POL'

No = Consecutive segment number
MaxOcc = Maximum occurrence of the segment/group
Counter = Counter of segment/group within the standard

St = Status
EDIFACT: M=Mandatory, C=Conditional
User specific: R=Required, O=Optional, D=Dependent,
A=Advised, N=Not used

EURO-LOG AIR/SEA/ROAD/RAIL FREIGHT TMS IFTSTA

Segments

Group:	SG4	Status: C	MaxOcc: 99999	Counter: 0160 CNI-SG5
Group:	SG5	Status: R	MaxOcc: 99	Counter: 0200 STS-RFF-DTM-FTX-SG6-LOC-SG8-SG10
Group:	SG6	Status: C	MaxOcc: 9	Counter: 0260 NAD
Segment:	NAD	No: 21 Status: M	Level: 3 MaxOcc: 1	Counter: 0270 Name and address

		Standard	Implementation	
Tag	Name	St Format	St Format	Usage / Remarks
NAD				
3035	Party function code qualifier	M an..3	M an..3	EL Event location
C082	Party identification details	C	N	
3039	Party identifier	M an..35	N an..35	Not used
1131	Code list identification code	C an..17	N an..17	Not used
3055	Code list responsible agency code	C an..3	N an..3	Not used
C058	Name and address	C	C	
3124	Name and address description	M an..35	M an..35	Event place
3124	Name and address description	C an..35	N an..35	Not used
3124	Name and address description	C an..35	N an..35	Not used
3124	Name and address description	C an..35	N an..35	Not used
3124	Name and address description	C an..35	N an..35	Not used
C080	Party name	C	N	
3036	Party name	M an..35	N an..35	Not used
3036	Party name	C an..35	N an..35	Not used
3036	Party name	C an..35	N an..35	Not used
3036	Party name	C an..35	N an..35	Not used
3036	Party name	C an..35	N an..35	Not used
3045	Party name format code	C an..3	N an..3	Not used
C059	Street	C	N	
3042	Street and number or post office box identifier	M an..35	N an..35	Not used
3042	Street and number or post office box identifier	C an..35	N an..35	Not used
3042	Street and number or post office box identifier	C an..35	N an..35	Not used
3042	Street and number or post office box identifier	C an..35	N an..35	Not used
3164	City name	C an..35	N an..35	Not used
C819	Country sub-entity details	C	N	
3229	Country sub-entity name code	C an..9	N an..9	Not used
1131	Code list identification code	C an..17	N an..17	Not used
3055	Code list responsible agency code	C an..3	N an..3	Not used
3228	Country sub-entity name	C an..70	N an..70	Not used

No = Consecutive segment number
MaxOcc = Maximum occurrence of the segment/group
Counter = Counter of segment/group within the standard

St = Status
EDIFACT: M=Mandatory, C=Conditional
User specific: R=Required, O=Optional, D=Dependent,
A=Advised, N=Not used

EURO-LOG AIR/SEA/ROAD/RAIL FREIGHT TMS IFTSTA

Segments

		Standard	Implementation	
Tag	Name	St Format	St Format	Usage / Remarks
3251	Postal identification code	C an..17	C an..17	Event postal code
3207	Country name code	C an..3	C an..3	Event country

Remark:

Example:

NAD+EL++Place+++++XXXXX+DE'

No = Consecutive segment number
MaxOcc = Maximum occurrence of the segment/group
Counter = Counter of segment/group within the standard

St = Status
EDIFACT: M=Mandatory, C=Conditional
User specific: R=Required, O=Optional, D=Dependent,
A=Advised, N=Not used

EURO-LOG AIR/SEA/ROAD/RAIL FREIGHT TMS IFTSTA

Segments

Group:	SG4	Status: C	MaxOcc: 99999	Counter: 0160 CNI-SG5
Group:	SG5	Status: R	MaxOcc: 99	Counter: 0200 STS-RFF-DTM-FTX-SG6-LOC-SG8-SG10
Segment:	LOC	No: 22 Status: C	Level: 3 MaxOcc: 1	Counter: 0310 Place/location identification

		Standard	Implementation	
Tag	Name	St Format	St Format	Usage / Remarks
LOC				
3227	Location function code qualifier	M an..3	M an..3	172 Reporting location
C517	Location identification	C	N	
3225	Location name code	C an..25	N an..25	Not used
1131	Code list identification code	C an..17	N an..17	Not used
3055	Code list responsible agency code	C an..3	N an..3	Not used
3224	Location name	C an..256	N an..256	Not used
C519	Related location one identification	C	C	
3223	First related location name code	C an..25	C an..25	Geo coordinates
1131	Code list identification code	C an..17	N an..17	Not used
3055	Code list responsible agency code	C an..3	N an..3	Not used
3222	First related location name	C an..70	N an..70	Not used
C553	Related location two identification	C	N	
3233	Second related location name code	C an..25	N an..25	Not used
1131	Code list identification code	C an..17	N an..17	Not used
3055	Code list responsible agency code	C an..3	N an..3	Not used
3232	Second related location name	C an..70	N an..70	Not used
5479	Relation code	C an..3	N an..3	Not used

Remark:

Example:

LOC+172++11.608846,165.382019'

No = Consecutive segment number
MaxOcc = Maximum occurrence of the segment/group
Counter = Counter of segment/group within the standard

St = Status
EDIFACT: M=Mandatory, C=Conditional
User specific: R=Required, O=Optional, D=Dependent,
A=Advised, N=Not used

EURO-LOG AIR/SEA/ROAD/RAIL FREIGHT TMS IFTSTA

Segments

Group:	SG4	Status: C	MaxOcc: 99999	Counter: 0160 CNI-SG5
Group:	SG5	Status: R	MaxOcc: 99	Counter: 0200 STS-RFF-DTM-FTX-SG6-LOC-SG8-SG10
Group:	SG8	Status: C	MaxOcc: 99	Counter: 0330 TDT
Segment:	TDT	No: 23 Status: M	Level: 3 MaxOcc: 1	Counter: 0340 Details of transport

		Standard	Implementation	
Tag	Name	St Format	St Format	Usage / Remarks
TDT				
8051	Transport stage code qualifier	M an..3	M an..3	20 Main-carriage transport
8028	Means of transport journey identifier	C an..17	C an..17	Shipping line
C220	Mode of transport	C	C	
8067	Transport mode name code	C an..3	C an..3	10 Maritime transport 20 Rail transport 30 Road transport 40 Air transport 50 Mail 60 Multimodal transport
8066	Transport mode name	C an..17	N an..17	Not used
C228	Transport means	C	C	
8179	Transport means description code	C an..8	C an..8	6 Aircraft 13 Ocean vessel 31 Truck 74 Train
8178	Transport means description	C an..17	C an..17	Sea freight voyage number
C040	Carrier	C	C	
3127	Carrier identifier	C an..17	C an..17	Sea = IMO number Road = MainRoadCarrier Air = 2 letter airline code of Airline (e.g. AF)
1131	Code list identification code	C an..17	N an..17	Not used
3055	Code list responsible agency code	C an..3	N an..3	Not used
3128	Carrier name	C an..35	C an..35	Carrier name
8101	Transit direction indicator code	C an..3	N an..3	Not used
C401	Excess transportation information	C	N	
8457	Excess transportation reason code	M an..3	N an..3	Not used
8459	Excess transportation responsibility code	M an..3	N an..3	Not used
7130	Customer shipment authorisation identifier	C an..17	N an..17	Not used
C222	Transport identification	C	C	
8213	Transport means identification	C an..9	C an..9	10 Truck License plate number

No = Consecutive segment number
MaxOcc = Maximum occurrence of the segment/group
Counter = Counter of segment/group within the standard

St = Status
EDIFACT: M=Mandatory, C=Conditional
User specific: R=Required, O=Optional, D=Dependent,
A=Advised, N=Not used

EURO-LOG AIR/SEA/ROAD/RAIL FREIGHT TMS IFTSTA

Segments

		Standard	Implementation	
Tag	Name	St Format	St Format	Usage / Remarks
	name identifier			30 Name of the ship 40 Flight number 70 Train number
1131	Code list identification code	C an..17	N an..17	Not used
3055	Code list responsible agency code	C an..3	N an..3	Not used
8212	Transport means identification name	C an..35	C an..35	In case of 10 Track License plate number In case of 30 Name of the ship In case of 40 Flight number without airline code In case of 70 Train number
8453	Transport means nationality code	C an..3	N an..3	Not used
8281	Transport means ownership indicator code	C an..3	N an..3	Not used

Remark:

Example:

TDT+20+ShippingLine+10+13:VoyageNumber+IMONumber:::CarrierName+++10:::Ship name'

No = Consecutive segment number
MaxOcc = Maximum occurrence of the segment/group
Counter = Counter of segment/group within the standard

St = Status
EDIFACT: M=Mandatory, C=Conditional
User specific: R=Required, O=Optional, D=Dependent,
A=Advised, N=Not used

EURO-LOG AIR/SEA/ROAD/RAIL FREIGHT TMS IFTSTA

Segments

Group:	SG4	Status: C	MaxOcc: 99999	Counter: 0160 CNI-SG5
Group:	SG5	Status: R	MaxOcc: 99	Counter: 0200 STS-RFF-DTM-FTX-SG6-LOC-SG8-SG10
Group:	SG10	Status: C	MaxOcc: 99	Counter: 0400 EQD-MEA-SEL
Segment:	EQD	No: 24 Status: M	Level: 3 MaxOcc: 1	Counter: 0410 Equipment details

		Standard	Implementation	
Tag	Name	St Format	St Format	Usage / Remarks
EQD				
8053	Equipment type code qualifier	M an..3	M an..3	CN Container TE Trailer AQ License plate
C237	Equipment identification	C	C	
8260	Equipment identifier	C an..17	C an..17	
1131	Code list identification code	C an..17	N an..17	Not used
3055	Code list responsible agency code	C an..3	N an..3	Not used
3207	Country name code	C an..3	N an..3	Not used
C224	Equipment size and type	C	C	
8155	Equipment size and type description code	C an..10	C an..10	220 20ft GP ISO:22G0 221 20ft RF ISO:22R1 420 40ft GP ISO:42G0 450 40ft HC ISO:45G0 421 40ft RF ISO:42R1 L51 45ft HC ISO:L5G1 551 53ft HC (No ISO-Code) XXX No equipment ordered CNO Other Container
1131	Code list identification code	C an..17	N an..17	Not used
3055	Code list responsible agency code	C an..3	N an..3	Not used
8154	Equipment size and type description	C an..35	N an..35	Not used
8077	Equipment supplier code	C an..3	N an..3	Not used
8249	Equipment status code	C an..3	N an..3	Not used
8169	Full or empty indicator code	C an..3	N an..3	Not used

Remark:

Example:

EQD+CN+X+220'

No = Consecutive segment number
MaxOcc = Maximum occurrence of the segment/group
Counter = Counter of segment/group within the standard

St = Status
EDIFACT: M=Mandatory, C=Conditional
User specific: R=Required, O=Optional, D=Dependent,
A=Advised, N=Not used

EURO-LOG AIR/SEA/ROAD/RAIL FREIGHT TMS IFTSTA

Segments

Group:	SG4	Status: C	MaxOcc: 99999	Counter: 0160 CNI-SG5
Group:	SG5	Status: R	MaxOcc: 99	Counter: 0200 STS-RFF-DTM-FTX-SG6-LOC-SG8-SG10
Group:	SG10	Status: C	MaxOcc: 99	Counter: 0400 EQD-MEA-SEL
Segment:	MEA	No: 25 Status: C	Level: 4 MaxOcc: 9	Counter: 0420 Measurements

		Standard	Implementation	
Tag	Name	St Format	St Format	Usage / Remarks
MEA				
6311	Measurement purpose code qualifier	M an..3	M an..3	WT Weights
C502	Measurement details	C	C	
6313	Measured attribute code	C an..3	C an..3	T Tare weight
6321	Measurement significance code	C an..3	N an..3	Not used
6155	Non-discrete measurement name code	C an..17	N an..17	Not used
6154	Non-discrete measurement name	C an..70	N an..70	Not used
C174	Value/range	C	C	
6411	Measurement unit code	M an..3	M an..3	KGM kilogram
6314	Measurement value	C an..18	C an..18	Solus VGM weight
6162	Range minimum value	C n..18	N n..18	Not used
6152	Range maximum value	C n..18	N n..18	Not used
6432	Significant digits quantity	C n..2	N n..2	Not used
7383	Surface or layer code	C an..3	N an..3	Not used

Remark:

Example:

MEA+WT+T+KGM: 35.5'

No = Consecutive segment number
MaxOcc = Maximum occurrence of the segment/group
Counter = Counter of segment/group within the standard

St = Status
EDIFACT: M=Mandatory, C=Conditional
User specific: R=Required, O=Optional, D=Dependent,
A=Advised, N=Not used

EURO-LOG AIR/SEA/ROAD/RAIL FREIGHT TMS IFTSTA

Segments

Group:	SG4	Status: C	MaxOcc: 99999	Counter: 0160 CNI-SG5
Group:	SG5	Status: R	MaxOcc: 99	Counter: 0200 STS-RFF-DTM-FTX-SG6-LOC-SG8-SG10
Group:	SG10	Status: C	MaxOcc: 99	Counter: 0400 EQD-MEA-SEL
Segment:	SEL	No: 26 Status: C	Level: 4 MaxOcc: 9	Counter: 0440 Seal number

		Standard	Implementation	
Tag	Name	St Format	St Format	Usage / Remarks
SEL				
9308	Seal identifier	C an..35	C an..35	
C215	Seal issuer	C	N	
9303	Sealing party name code	C an..3	N an..3	Not used
1131	Code list identification code	C an..17	N an..17	Not used
3055	Code list responsible agency code	C an..3	N an..3	Not used
9302	Sealing party name	C an..35	N an..35	Not used
4517	Seal condition code	C an..3	N an..3	Not used
C208	Identity number range	C	N	
7402	Object identifier	M an..35	N an..35	Not used
7402	Object identifier	C an..35	N an..35	Not used

Remark:

Example:

SEL+X'

No = Consecutive segment number
MaxOcc = Maximum occurrence of the segment/group
Counter = Counter of segment/group within the standard

St = Status
EDIFACT: M=Mandatory, C=Conditional
User specific: R=Required, O=Optional, D=Dependent,
A=Advised, N=Not used

EURO-LOG AIR/SEA/ROAD/RAIL FREIGHT TMS IFTSTA

Segments

Segment: **UNT** No: 27 Level: 0 Counter: 0660
Status: M MaxOcc: 1 **Message trailer**

		Standard	Implementation	
Tag	Name	St Format	St Format	Usage / Remarks
UNT				
0074	Number of segments in the message	M n..6	M n..6	
0062	Message reference number	M an..14	M an..14	

Remark:

Example:

UNT+25+X'

No = Consecutive segment number
MaxOcc = Maximum occurrence of the segment/group
Counter = Counter of segment/group within the standard

St = Status
EDIFACT: M=Mandatory, C=Conditional
User specific: R=Required, O=Optional, D=Dependent,
A=Advised, N=Not used

EURO-LOG AIR/SEA/ROAD/RAIL FREIGHT TMS IFTSTA

Segments

Segment: **UNZ** No: 28 Level: 0 Counter: 0000
Status: M MaxOcc: 1 Interchange trailer

		Standard	Implementation	
Tag	Name	St Format	St Format	Usage / Remarks
UNZ				
0036	Interchange control count	M n..6	M n..6	
0020	Interchange control reference	M an..14	M an..14	

Remark:

Example:

UNZ+1+X'

No = Consecutive segment number
MaxOcc = Maximum occurrence of the segment/group
Counter = Counter of segment/group within the standard

St = Status
EDIFACT: M=Mandatory, C=Conditional
User specific: R=Required, O=Optional, D=Dependent,
A=Advised, N=Not used

EURO-LOG AIR/SEA/ROAD/RAIL FREIGHT TMS IFTSTA

Example Message

No	Tag	Segment example
01	UNA	UNA:+.? '
02	UNB	UNB+UNOC:3+Sender+EUROLOG+191017:1616+X'
03	UNH	UNH+X+IFTSTA:D:01B:UN'
04	BGM	BGM+7+X+9'
05	DTM	DTM+137:201906281331:203'
	SG4	
06	CNI	CNI+1+SONXXXXXXXXXXXXX'
	SG5	
07	STS	STS+1+13'
08	RFF	RFF+AAZ:XXXXXXXXXXXXX'
09	RFF	RFF+BL:XXXXXXXXXXXXX'
10	RFF	RFF+BN:XXXXXXXXXXXXX'
11	RFF	RFF+CMR:XXXXXXXXXXXXX'
12	RFF	RFF+CU:XXXXXXXXXXXXX'
13	RFF	RFF+CUS:XXXXXXXXXXXXX'
14	RFF	RFF+FN:XXXXXXXXXXXXX'
15	RFF	RFF+HBL:XXXXXXXXXXXXX'
16	RFF	RFF+PBN:XXXXXXXXXXXXX'
17	RFF	RFF+SRN:XXXXXXXXXXXXX'
18	DTM	DTM+70:201906281244:203'
19	FTX	FTX+TRA+++X:X:X:X:X'
	SG6	
20	NAD	NAD+TR+X+POL'
	SG6	
21	NAD	NAD+EL++Place+++++XXXXX+DE'
22	LOC	LOC+172++11.608846,165.382019'
	SG8	
23	TDT	TDT+20+ShippingLine+10+13:VoyageNumber+IMONumber:::CarrierName+++10:::S hip name'
	SG10	
24	EQD	EQD+CN+X+220'
25	MEA	MEA+WT+T+KGM:35.5'
26	SEL	SEL+X'
27	UNT	UNT+25+X'
28	UNZ	UNZ+1+X'

No = Consecutive segment number

EURO-LOG AIR/SEA/R

IFTSTA / UN D.01B S3

Issue date 9/24/2024

Print date 9/24/2024

Vertraulich/Confidential

Generated by GEFEG.FX